

071505T4WAF

WELDING AND FABRICATION LEVEL 5

ENG/OS/WEF/CR/06/5

Perform Spot and Seam Resistance Welding

July/August 2025



**TVET CURRICULUM DEVELOPMENT, ASSESSMENT AND CERTIFICATION
COUNCIL (TVET CDACC)**

PRACTICAL ASSESSMENT

Time: 6 HOURS

INSTRUCTIONS TO CANDIDATE

1. You are required to perform the following tasks;
 - i. Prepare parts as per the working drawing
 - ii. Carryout Spot and Seam Resistance Welding as per the working drawing
2. You have been provided with the following resources for the practical task:
 - Gauge 18 Mild Steel sheet 305 mm × 205 mm (2 off)
 - Gauge 18 Mild Steel sheet 155 mm × 155 mm (1 off)
 - Spot Welding machine and accessories
 - Seam Welding machine and accessories
 - Bench with vices
 - Plastic hammer

- Mallet
- Hand shears or snips
- Stakes and stake holder
- Scriber
- Hacksaw frame and blade
- Steel rule
- Try square
- Metre rule
- Steel tape
- Assorted Files
- Divider
- Flat edge
- Hand seamer
- A4 Plain paper

easyvet.com

WORKING DRAWING

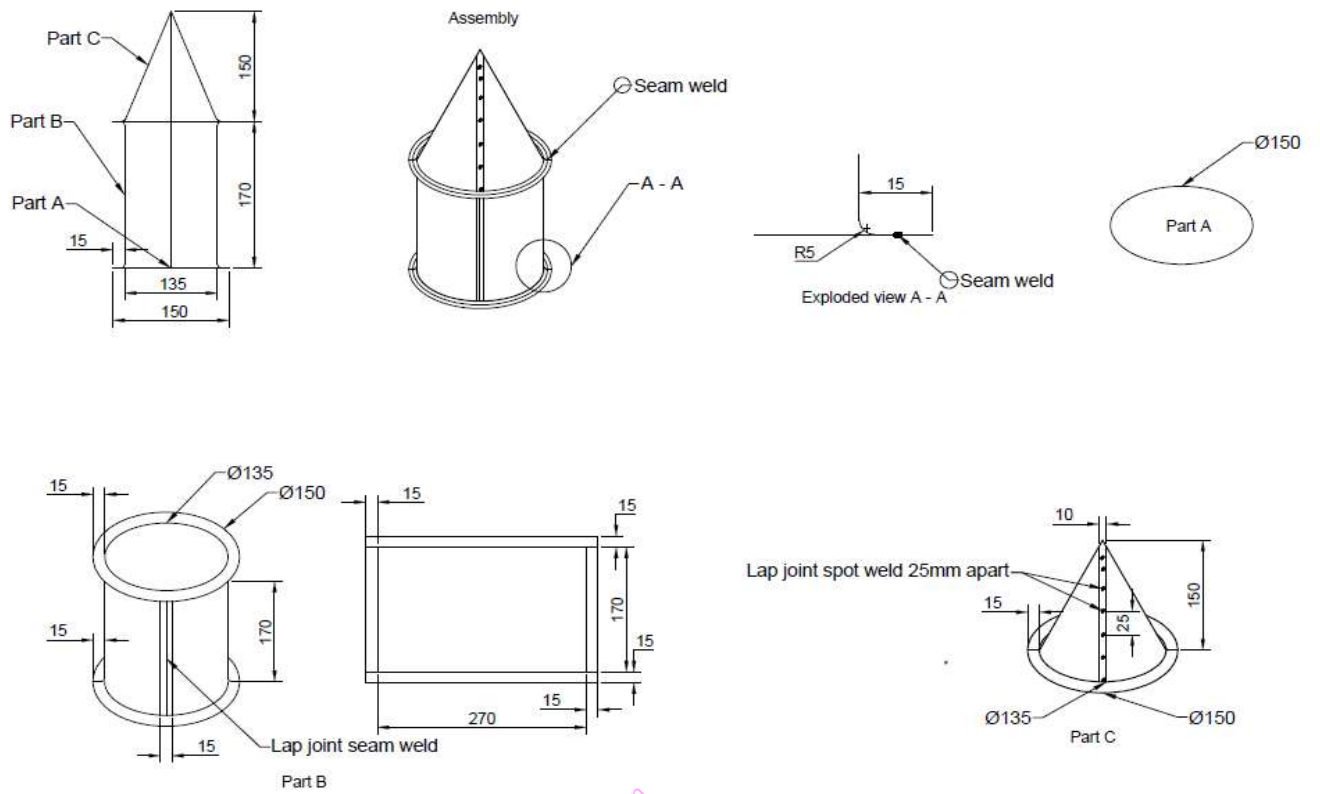

Notes: All dimensions are in mm.