

**061906T4TEL**

**TELECOMMUNICATION ENGINEERING LEVEL 6**

**ENG/OS/TLE/CR/02/6/A**

**Install Base Transceiver Station**

**Nov/ Dec 2024.**



**TVET CURRICULUM DEVELOPMENT, ASSESSMENT AND CERTIFICATION  
COUNCIL (TVET CDACC)**

**PRACTICAL ASSESSMENT**

**TIME: 2 HOURS**

**INSTRUCTIONS TO CANDIDATE:**

1. Figures 1 and 2 show circuit diagrams for a radio frequency transmitter and receiver.  
You are required to assemble and test the operation of the radio frequency transmitter and receiver circuit.  
**TASK 1:** Assemble the transmitter circuit in **Figure 1** separately on a breadboard. **DO NOT** connect the battery or power source first.  
**TASK 2:** Assemble the receiver circuit in **Figure 2** separately on a breadboard. **DO NOT** connect the battery or power source first.  
**TASK 3:** Check for continuity in the connections to ensure there are no open circuits.  
**TASK 4:** Power both the transmitter and receiver circuits. Press the push- button on the transmitter circuit and record observations made on the receiver circuit.

**TASK 5:** Test the range of the wireless communication by gradually increasing the distance between the transmitter and receiver in intervals of 25cm. Record the maximum effective range.

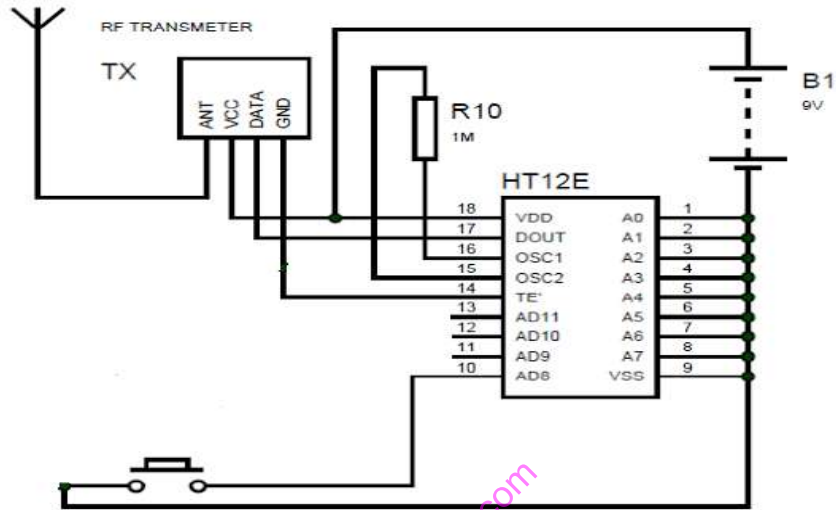

Figure 1: Transmitter circuit diagram

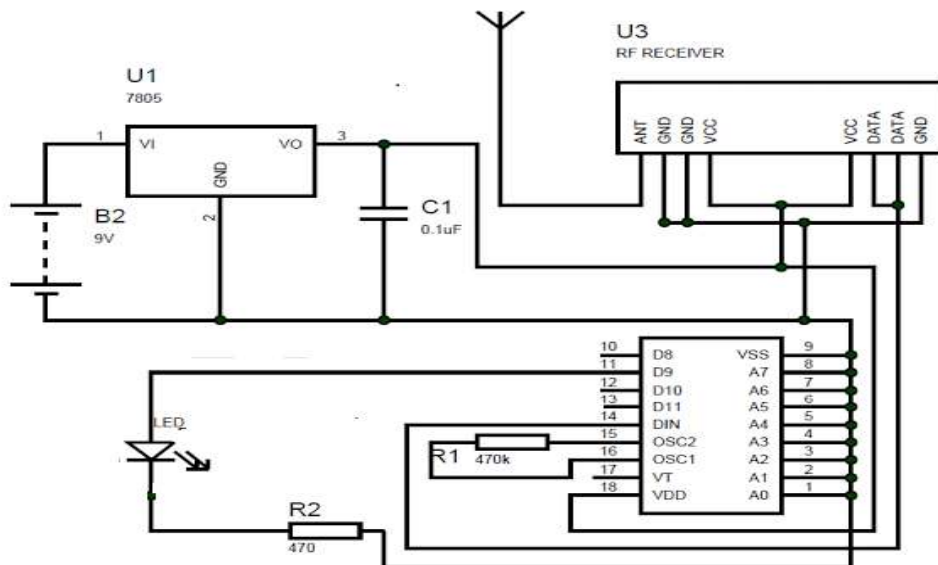

Figure 2: Receiver circuit diagram

2. You are provided with the following resources to perform the tasks:

**Transmitter circuit components:**

- i. 1 pc- 433MHz RF transmitter module
- ii. 1 pc- Encoder IC (HT12E)
- iii. 1pc - push button switch
- iv. Jumper wires
- v. 1 pc - breadboard
- vi. 9V battery
- vii. 1 pc- 1M $\Omega$  resistor

**Receiver Circuit Components**

- i. 1 pc- 433MHz RF receiver module
- ii. 1 pc- Decoder IC (HT12D)
- iii. 1 pc- Breadboard
- iv. Jumper wires
- v. 9V battery
- vi. 1 pc - LED
- vii. 1 pc- 470 $\Omega$  resistor
- viii. 1 pc- 470k $\Omega$  resistor
- ix. 7805 Voltage regulators
- x. 0.1  $\mu$ F Capacitor
- xi. Digital Multimeter
- xii. 9V Battery connector clip

easyvet.com