

**071505T4WAF**

**WELDING AND FABRICATION LEVEL 5**

**ENG/OS/WEF/CR/04/5**

**Perform Gas Metal Arc Welding (GMAW)**

**July/August 2025**



**TVET CURRICULUM DEVELOPMENT, ASSESSMENT AND CERTIFICATION  
COUNCIL (TVET CDACC)**

**PRACTICAL ASSESSMENT**

**Time: 8 HOURS**

**INSTRUCTIONS TO CANDIDATE:**

1. You are required to perform the following tasks;
  - i. Prepare parts as per the working drawing
  - ii. Carryout Gas Metal Arc Welding (GMAW) as per the working drawing
2. You have been provided with the following resources for the practical tasks:
  - Mild Steel plates
    - 122 mm × 45 mm × 5 mm (6 off)
  - Complete Gas Metal Arc (GMAW) Welding equipment and accessories
  - Try square
  - Tape measure
  - Steel rule
  - Hacksaw frame and blade
  - Leather gloves

- Vernier caliper
- Assorted files
- Bench with vices
- Welding shield
- Angle grinder
- Grinding disc
- Metal wire brush
- Pair of tongs
- A4 plain paper

[easyvet.com](http://easyvet.com)

**WORKING DIAGRAM**

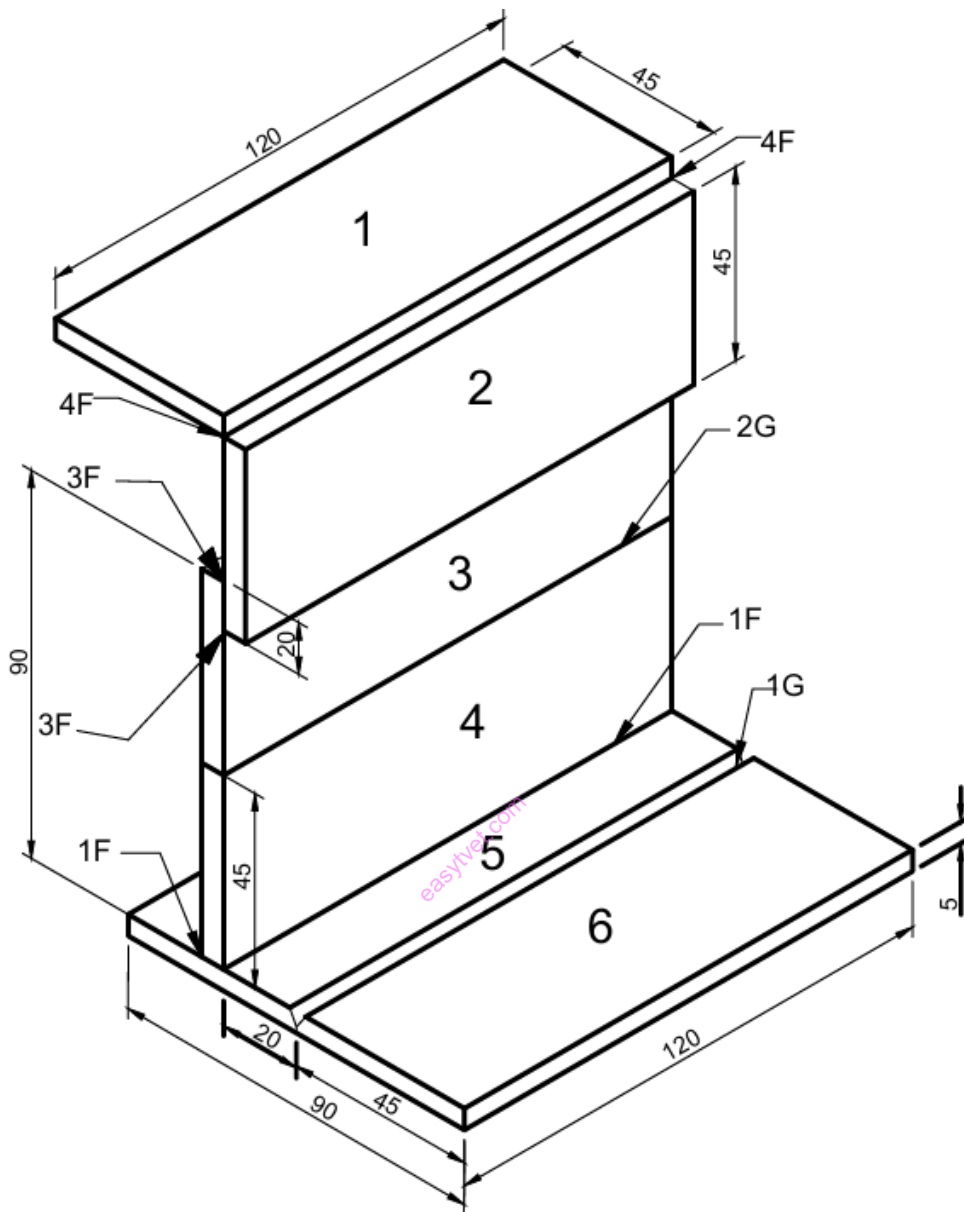

**NOTES: All dimensions are in millimeters (mm)**

**Tolerance  $\pm 1$  mm**