

**0732 3GYPMA**

**GYPSUM INSTALLATION LEVEL 3**

**CON/OS/GYP/CR/02/3/MA**

**Install Gypsum Partitions**

**July/August 2025**



**TVET CURRICULUM DEVELOPMENT, ASSESSMENT AND CERTIFICATION  
COUNCIL (TVET CDACC)**

**PRACTICAL ASSESSMENT**

**INSTRUCTIONS TO THE CANDIDATE:**

1. This unit of competence shall be assessed in three phases.
2. Each assessment session has the duration included in brackets
3. The third phase of the assessment shall include a practical session and an oral assessment session.
4. The assessor will take photos and videos as you perform the tasks at critical points during the assessment.
5. Ensure all required resources for the assessment have been provided before beginning the assessment.

## **1. PRACTICAL ASSESSMENT 1 (4 HOURS)**

### **Elements Covered**

- Construct gypsum partition framing

### **Tasks:**

- a. Set out the layout using appropriate tools as per job description.
- b. Fix bottom and top tracks as per working drawing.
- c. Install vertical studs and horizontal bracings according to working drawing.
- d. Check frame plumbness and alignment keenly.

## **2. PRACTICAL ASSESSMENT 2 (4 HOURS)**

### **Elements Covered**

- Install gypsum partition boards

### **Tasks:**

- a. Measure dimensions and cut gypsum boards as per working drawing.
- b. Position boards on frame as in the drawing.
- c. Fasten boards correctly and carefully.
- d. Perform end-of-task housekeeping as per work place procedure.

## **3. PRACTICAL ASSESSMENT 3 (4 HOURS) AND ORAL ASSESSMENT (3 HOURS)**

### **Elements Covered**

- Apply finishes to gypsum partition boards surfaces

### **Tasks:**

- a. Prepare joint surfaces and apply joint compound (3 coats) with tape as per job description.
- b. Skim and sand board surfaces as per instructions given.
- c. Apply primer evenly and correctly.

The assessor will proceed to ask you oral questions for 1 hour.

**EXISTING WALL**

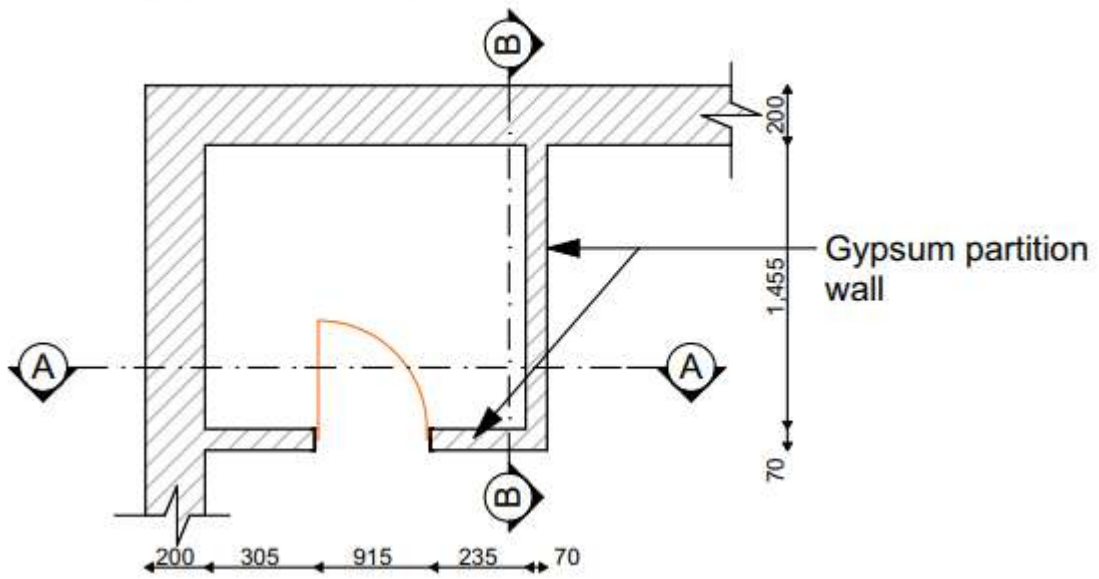

**FLOOR PLAN**

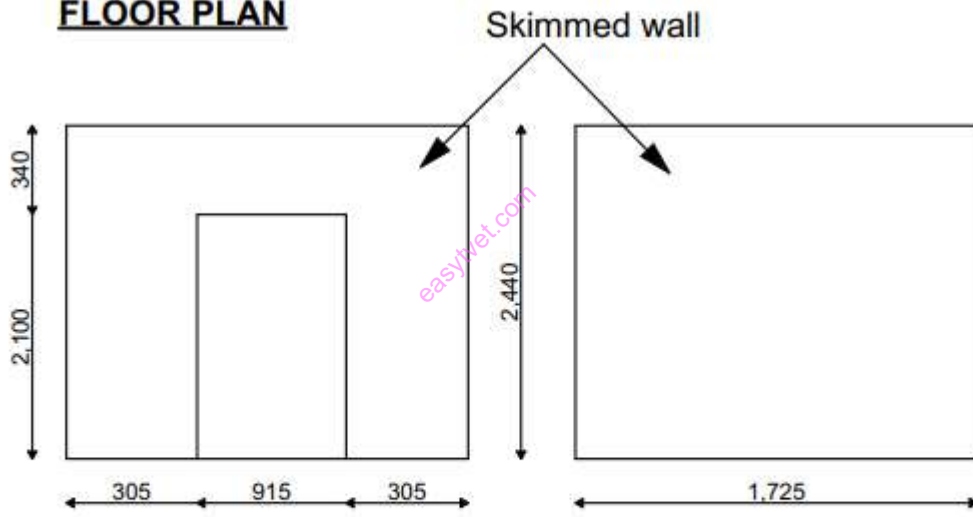

**SECTION A-A**

Finished partition wall

**SECTION B-B**

Finished partition wall

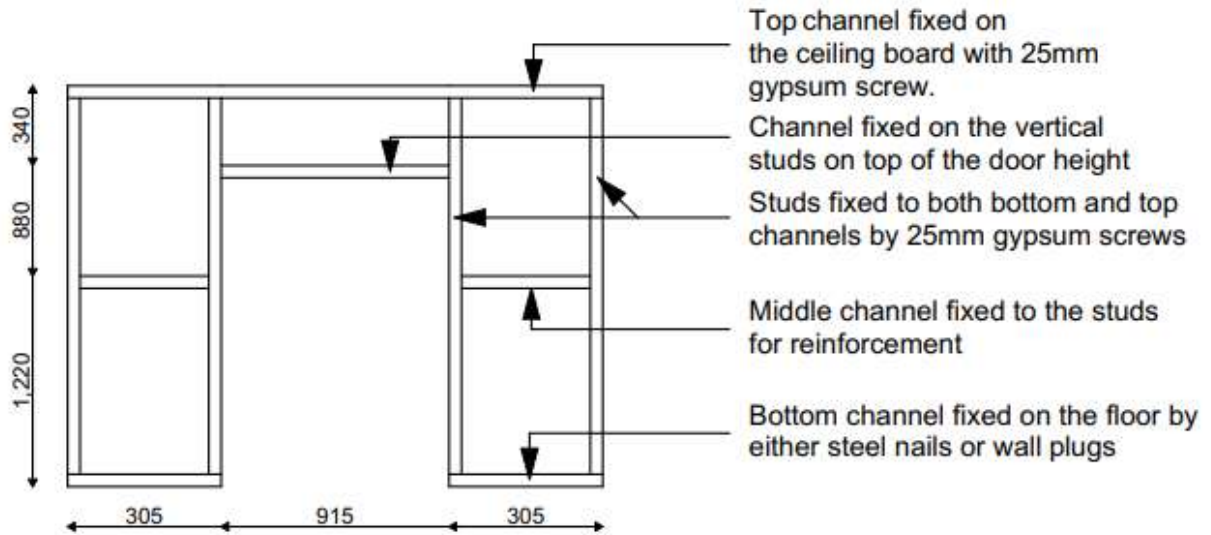

**SECTION A-A ; Framed structure**

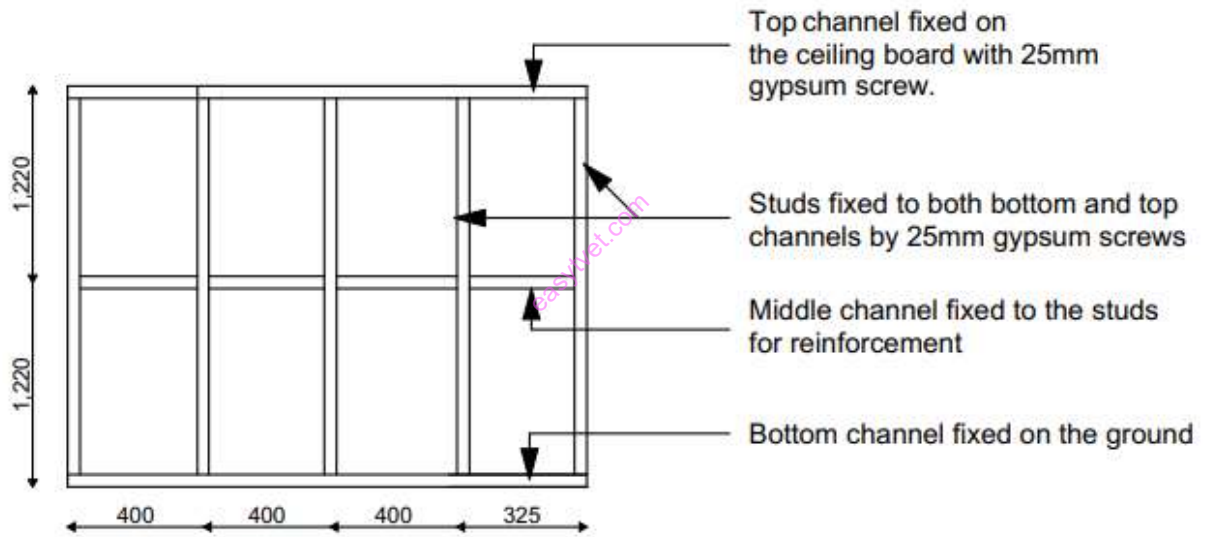

**SECTION B-B ; Framed structure**

**WORKING DRAWING**