

**071505T4WAF**

**WELDING AND FABRICATION LEVEL 5**

**ENG/OS/WEF/CR/02/5**

**Perform Soldering and Gas Welding**

**July/August 2025**



**TVET CURRICULUM DEVELOPMENT, ASSESSMENT AND CERTIFICATION  
COUNCIL (TVET CDACC)**

**PRACTICAL ASSESMENT**

**Time: 8 HOURS**

**INSTRUCTIONS TO CANDIDATE**

1. You are required to perform the following tasks;
  - i. Prepare the parts as per the working drawing
  - ii. Carryout Gas welding as shown on the working drawing
2. You have been provided with the following resources for the practical task:
  - Mild steel Plates
    - 102 mm × 82 mm × 3 mm      1 off
    - 102 mm × 52 mm × 3 mm      2 off
    - 82 mm × 52 mm × 3 mm      1 off
  - Mild steel pipe
    - Ø50 mm × 52 mm      1 off
  - Complete Gas welding equipment and its' accessories

- Scriber
- A4 Plain paper
- Steel rule
- Try Square
- Anvil
- Ball pein hammer
- Chipping hammer
- Protractor
- Metal wire brush
- Hack saw frame and blade
- Bench with vices
- Pair of tongs
- Angle grinder
- Grinding disc
- Assorted files
- Leather gloves
- Welding goggles
- Clear goggles
- Leather Apron
- Overall/Dust coat
- Safety boots/Leather shoes

[easytvet.com](http://easytvet.com)

**WORKING DRAWING**

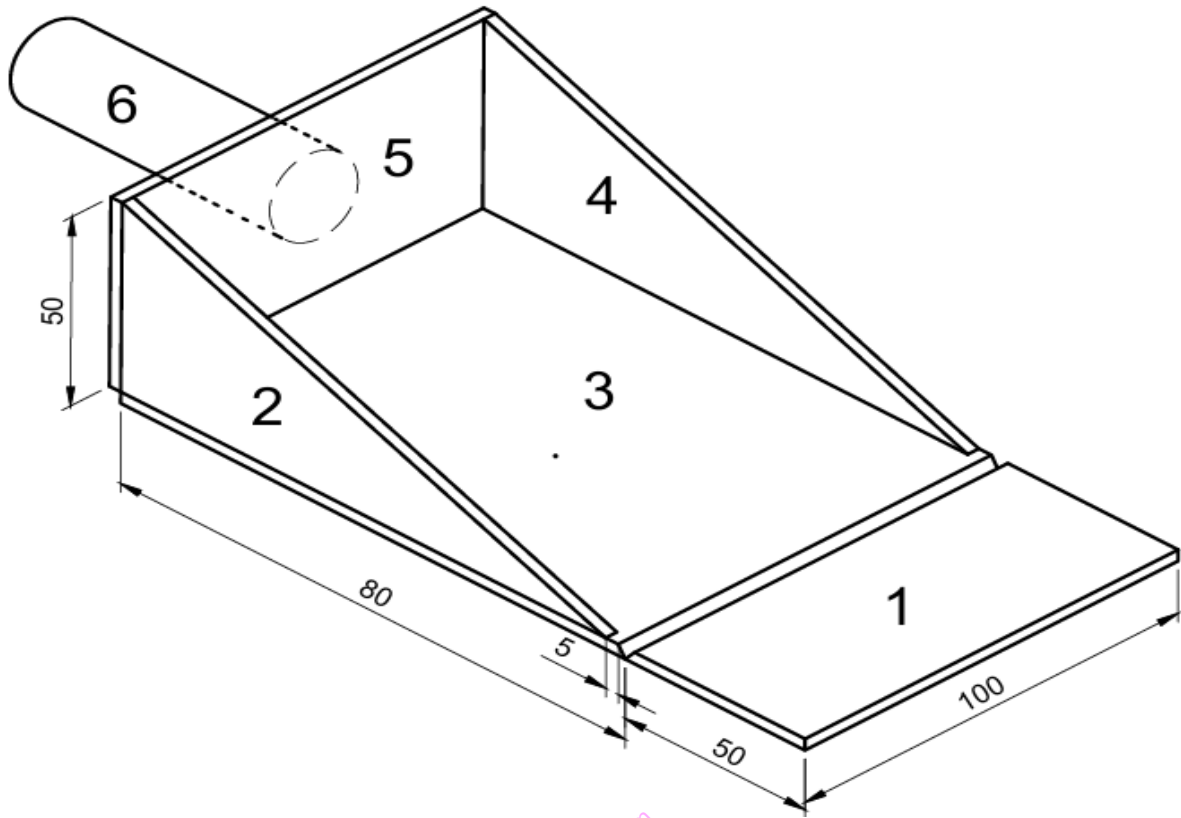

**NOTES: All dimensions are in mm**

[easyvet.com](http://easyvet.com)