

# EFFECT OF TAX FILLING PROCEDURE AND ACCOUNTABILITY ON TAX COMPLIANCE AMONGST SMES IN NAKURU COUNTY KENYA

**Robin Aondo & Isabella Sile**

**<sup>1\*</sup>Robin Mariita Aondo**

*<sup>1</sup>Post Graduate Student: Management University of Africa*

*\*Corresponding Author's Email: mariitarobin@yahoo.com*

**<sup>2\*</sup>Ms. Isabella Sile**

*Lecturer: Management University of Africa*

## **Abstract**

*The study aimed at determining the effect of filling procedure and accountability compliance amongst SMEs in Nakuru County Kenya. The study employed descriptive research design. The data collection was done by asking the respondents structured and pre-determined questions. The target population of the study comprised of Small and medium Enterprises in Nakuru County which were 1,425 SMEs operating within the township, concentrating within the manufacturing, trade and services sectors. The study adopted stratified random sampling technique to select 10% of the target population therefore giving a sample size of 142 respondents and the valid respondents in the study were 119 respondents. The researcher utilized questionnaire as the essential instrument for information gathering. Data gathered from correctly filled questionnaires were coded, tabulated and analyzed using SPSS by both descriptive statistics which include mean and standard deviation to capture the characteristics of the variables under study. Inferential statistics were also used to analyze the relationship of tax compliance and the filling procedure and accountability. The results were then presented through Figures and Tables. Regression results revealed that filling procedure and accountability had positive and significant effect on tax compliance amongst SMEs in Nakuru County Kenya. This means that an increase in tax payers knowledge and tax rates led to an improvement in tax compliance.: The study recommended that filling procedure should not be complex so as to not contribute to wrong tax returns, also lessen measure of time taken for organizations to round out various structures with comparative data, moreover the study recommended there to be Tax accountability and transparency with greater emphasis on the various kinds of taxes such as Personal Income Tax, Companies Income Tax, Petroleum profit Tax, Duties and value Added Tax since they are perceived to have a direct correlation with the Gross Domestic Product (GDP).*

**Keywords:** Filling procedure, accountability, tax compliance and SMEs

## Background of the Study

Globally the estimates show the extent of tax avoidance in Italy loses €183 billion, or \$242 billion, to tax evasion a year, and its debt of €1.9 trillion represents just over 10 years of tax evasion (European Union, 2017). According to EU nations such as Italy and Greece have pledged seriousness about evasion of tax and money exchanges for merchandise and enterprises falling underneath the radar of authorities. Germany and Britain consented to arrangement with Switzerland about recouping tax income from bank accounts retained in Swiss banks by their subjects. South America has worldwide big black market economy compared to its G.D.P. taken after by Europe and Africa, where salary avoided assessment experts totaling 20.5 percent of G.D.P, contrasts and 10.8 percent in North America (Association, 1998).

The African countries lose more than \$ 50 billion every year through tax avoidance and evasion (Economic Commission of African 2015). According to the report by Institute of Economic Affairs (2015) in East African, Uganda loses minimal sum in evaded taxes: In 2011, it lost 856 million United States dollars, trailed by Tanzania at 1.9 billion United States dollars; Kenya loses somewhat more than 2 billion USD. In 2011, the informal economy constituted 33% of the GDP in Kenya and spoke to 7% of aggregate government consumption. The taxation rate in Kenya would accordingly be high, remaining at around 20.9%. On the off chance that the Kenya government is to expand its social consumption, at that point it needs to diminish tax evasion in the informal economy and the deficit is squarely being blamed on tax found, low tax collection that is associated with complex filling procedures and the decline in import (Griffiths, 2005).

According to Kirchler (2007) citizens will never again have the will fund administration through tax compliance and therefore come about to dodging tax liabilities. Absence of obligation and receptiveness in funds use from people in general develop doubt amongst taxpayers towards arrangement of tax assessment and organization, subsequently influencing eagerness of levy payment by taxpayers. Because of abnormal amounts of fraud, taxpayers are not ready to learn whether taxes paid are utilized as a part of the financing of public merchandise and provision of services, prompting an adjustment in their ability to pay henceforth the probability they may avoid taxes. In the event that the lawful framework does not maintain the rule of law it will prompt decreased straightforwardness and cultivate doubt among residents. It is basic to build up wide data in regards to the determinants of compliance to tax in order to have the capacity to create measures for battling tax avoidance and evasion. The societal spirit to conform to assessment may upgrade a requirement of self to tax compliance. Nonetheless, tax morale, state of mind and conduct aren't set up, particularly in nations with where the culture is not to pay tax (Braughtigam *et.al.*, 2008). There is an immediate relationship of size and sort of punishments that non-compliers and tax compliance level. Deficiencies in tax accumulation might be consequence of frail limit of framework to identify and arraign tax violators. Utilization of relatives in SMEs through unpaid work likewise diminishes likelihood of recognition in this way affecting the choice of taxpayer with respect to compliance.

In Kenya, the SME segment is very extensive, evaluated at 34.3 percent and representing 77 percent of work statistics (Institute of Economic Affairs, 2015). More than 60 percent of people working in SMEs are young, aged between 18 to 35 years, half being women (Ouma, *et al.*, 2009). The initial 1993 SMEs benchmark overview uncovered around 910,000 small micro enterprises were utilizing approximate 2million individuals. Second SME standard overview (1995), assessed measure of SME segment at 708,000 endeavors utilizing up to 1.2 m individuals. Contrasted with alternate areas of the economy, commitment of small micro enterprises part to nation's GDP expanded from 13.8% in 1993 to more than 18% in every passing year. These SMEs are part of the main contributors to the economy of the Nakuru County as they create employment and purchase products hence directly supporting livelihoods. According to Ndemo (2015), most SMEs do not register for tax purposes and most of them operate without licenses from both the county and national governments. Thus, tax compliance issue is a serious problem in most of the SMEs.

## Statement of the Problem

A number of studies have been accomplished in developing nations in regard to tax compliance, more so in Kenya. Studies by Lumumba, Wanjohi and Magutu (2010) who analyzed how taxpayers attitude and influences impacts

compliance conduct among SMEs in Kerugoya town and reasoned that majority taxpayers see Kenyan tax framework as out of line, majority respondents varied payment of decent amount of tax; which neighbors and companions were filing ; Magiya (2016) directed an examination on tax compliance determinants amongst small and medium estimated undertakings in Nairobi east tax district and found that an expansion in the tax payers comprehension of the assessment laws and the tax framework as well as an increase in government accountability with regards to provision of public good and services results into higher compliance levels, thus more of funds through revenue collection; Thiga and Muturi (2015) conducted a study on Factors That impacts Tax Laws compliance amongst Kenyan SMEs and found tax rates and tax compliance expenses are highest tax compliance contributing factor. Of all these studies, there is an existing information gap that needs to address the effect of filing procedure and accountability on tax compliance amongst SMEs hence motivation for current study with reference to SMEs in Nakuru. Therefore the study intentions were to determine the effect of filing procedure and accountability on tax compliance amongst SMEs in Nakuru County Kenya.

## **Literature and Theoretical Review**

### **Institutional Anomie Theory (IAT)**

Anomie is a sociological theory that holds that individuals make decisions based on socialized values, which separately may be contradictory but together, balances each other out, producing behavior considered “normal” by society. When one holds an imbalanced set of values, decisions made on that set may produce deviant behavior, such as everyday crime (Itashiki, 2011). Specifically, the most recent rendition of anomie theory, institutional anomie theory (Messner & Rosenfeld, 2001) appears readily adaptable for examining the relationship between cultural values and tax evasion behaviors (Riahi-Belkaoui & Picur, 2000). Institutional Anomie Theory highlights four theoretically derived sets of national cultural dimensions likely to promote or suppress tax evasion. They include individualism, achievement orientation, assertiveness and humane orientation.

Individualistic cultural values set the stage for behaviors that emphasize the pursuit of firm self-interest, largely neglecting concern for ethical consequences. According to IAT, individualistic cultural values encourage firm's decision makers to choose goal achievement beyond concerns for the ethical or legal means to achieve goals (Bame-Aldred, Cullen, Martin & Parboteeah, 2011). Thus, in such societies, firms more willingly deviate from accepted norms and evade taxes. On the contrary, collectivist cultures favor allegiance to the greater collective rooted in the notion that societal members are interdependent (Triandis, 1995) and, as such should deter individual gains at the expense of the collective.

This suggests that individualistic cultural values should inflate temptations for firms to evade taxes. Deceiving the tax system and the dangers of being punished once detected of the cheating, and for this reason the individual will honor the tax compliance requirements for fear of being penalized. Needless to say, compliance amongst individual payment of tax has sustainably remained high over the years. Analytically, there is no support that enforcement by the relevant authorities could be responsible for making individuals comply. The ultimate idea with tax compliance is why less tax is paid than expected, not why tax payers evade paying taxes due.

### **Theory of Planned Behavior**

Intention is the cognitive representation of a person's readiness to perform a given behavior and is considered to be the immediate antecedent of behavior. Behavior is the translation of intention to action. The main hypothesis of the Theory of Planned Behavior is that there is one immediate determinant of behavior, namely the person's intention to perform or not perform it (Fishbein & Ajzen, 1975). This intention is itself, in turn, viewed as determined by three things: attitude, subjective norms and subjective control toward the specific behavior. More specifically, the Theory of Planned Behavior attempts to provide an account of the way in which attitude, subjective norms, subjective control and intentions combine to predict behavior (Fishbein & Ajzen, 1975). This theory is adopted for the study to shows intention to action by SMEs in filing procedure and accountability on tax compliance.

The Theory of Planned Behavior was proposed by Ajzen (1985) as an extension of the Theory of Reasoned Action, which had been proposed a decade earlier, by (Fishbein & Ajzen, 1975). According to the Theory of Reasoned Action, people are more likely to do a behavior if they evaluate the suggested behavior as having positive results (attitude) and if they think their significant others want them to perform the behavior (subjective norm). A high correlation of attitudes and subjective norms to behavior has been confirmed in many studies (Sheppard, Hartwick, & Warshaw, 1988). However, the same authors argued against the high relationship between attitude, subjective norms and behavior. They argued that because of circumstantial limitations, attitude and subjective norms do not always lead to behavior. To improve on the predictive power of the Theory of Reasoned Action Ajzen added a new component "perceived behavioral control" to help account for behaviors that arise where an individual's control over the behavior is incomplete. By this, he extended the Theory of Reasoned Action to include the role of non-volition in predicting behavior. The extended version is called the Theory of Planned Behaviour (Fishbein & Ajzen, 1975).

Behavioral, Normative and Control beliefs: In addition, the three predictors are determined as follows: Attitude is a function of behavioral belief or salient information, which is the perceived likelihood that performing the particular behavior will lead to certain consequences, weighted by the extent to which these consequences are valued (Fishbein & Ajzen, 1975). Subjective norm is a function of normative belief which is the perceived pressure from specified referents to perform the target behavior, weighted by the motivation to comply with the people one cares about. Perceived behavioral control is determined by control belief which is the perceived access to the necessary resources and opportunities to perform a behavior successfully, weighted by the perceived power or effect of the particular control factor (Fishbein & Ajzen, 1975).

## Literature Review

Tax compliance methodology incorporates every single formal system and related exercises that taxpayers need to see to conform to tax commitments. Tax commitments are ordered into four classes: Financial speculations on tax assessment holds that, taxpayers are flippant utility amplify and affected by monetary thought processes, for example, benefit expansion, in this manner, they examine elective compliance ways for example regardless of whether to dodge tax. Also there is wide discernment by taxpayer that taxation is a load particularly little and medium ventures (Vihanto, 2000). According to Isa (2012) Tax unpredictability is another detectable significance of taxpayers compliance factor impacting compliance conduct and it might be beginning of avoiding tax Moreover, Loo, McKerchar and Hansford (2010) focused that tax laws are excessively confounded for taxpayer', making it impossible to keep side by side thinking about the regular change in tax law. Authors saw tax many-sided quality as difficulty in tax law and successive tax law changes. These matters may conceivably be reason whereby taxpaying corporations set out services of outside tax experts when encountering challenges in issue taxation. Braithwaite (2001) contended that the taxpayers' evaluation of local tax bureau's performance is proposed to affect tax compliance. Thus, the extent to which the tax office is delivering on its charter is suggested to be a factor affecting compliance. Young et al. (2013) concurred to this as they put it that as tax authority is fulfilling its promise their willingness to follow tax requirement may be higher.

Kiow, Salleh and Kassim (2017) conducted a study on the Determinants of Individual Taxpayers' Tax Compliance Behaviour in Peninsular Malaysia. The findings from this review suggested that tax compliance behaviour of individual taxpayers is influenced by ethical perception of individual taxpayers and their ethical perception is affected by public governance and transparency in government operations. Ethical perception plays an important role for individual taxpayers to report their income correctly. Ethical perception varies from an individual to another, which influenced by changes in their surroundings and their experiences when interact with government. Perceptions of how taxpayers' money is being utilized, benefits they derived from government or others evade to pay tax are considered as possible factors influencing their compliance behavior. Taxpayers will be more compliance if government use tax monies wisely or when taxpayers get benefits for the taxes paid in terms of public goods and social amenities that they prefer. Transparent surroundings will enhance taxpayers' confidence in public bodies. Taxpayers are concerned on transparency in public procurement as lack of transparency may cause corruption and reduces public sector efficiency. In contrast, scholars argued that greater degree of transparency could lead to less trust as it will be easier for taxpayers to audit government and they might blame government for small mistakes.

## Conceptual Framework

Figure 1: Conceptual Framework

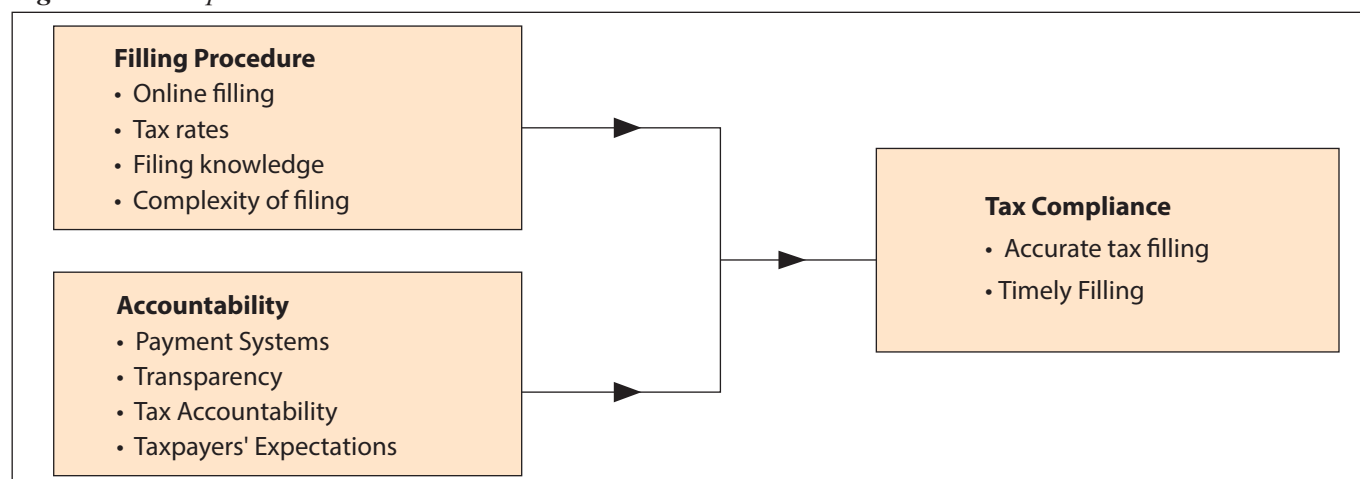

A conceptual framework is a virtual or written product, one that explains either graphically or in narrative form, the main things to be studied. A conceptual framework explores the relationship between independent variables and dependent variables. The conceptual framework for this study was based on the following independent variables: cost leadership strategy, differentiation strategy and focus strategy which influences the dependent variable firm performance.

## METHODOLOGY

The study adopted descriptive research design. The data collection was done by asking the target representative population structured and pre – determined questions. The target population of the study comprised of Small and medium Enterprises in Nakuru County which were 1,425 SMEs operating within the township, concentrating within the manufacturing, trade and services sectors. The study used stratified random sampling technique to select 10% of the target population therefore giving a sample size of 142 respondents. The researcher utilized questionnaire as the essential instrument for quantitative data. Study piloting was carried out before primary research to build up reliability and validity of instrument of information gathering (Mugenda and Mugenda, 2013). Cronbach's alpha was used to test the reliability of the measures in the questionnaire. The coefficient alpha was an appropriate measure of variance attributes to subjects and the attributable to the interaction between subject items. The internal reliability obtain the following scores Filling Procedure 0.8; Accountability 0.69 and Tax Compliance 0.77 this indicates the internal reliability of the instruments were reasonable of Cronbach's alpha 0.60 as the minimum level of acceptance.

Data gathered from 119 correctly filled questionnaires were coded, tabulated and analyzed using SPSS version 22 by both descriptive statistics which include mean and standard deviation to capture the characteristics of the variables under study. Inferential statistics were also used to analyze the relationship of the dependent and the independent variable. The results were then presented through Figures and Tables.

## FINDINGS

### Demographic Characteristics

The respondents were asked to indicate their gender. Majority of the respondents were male who represented 66% of the sample while 34% were female. This implies that majority of the owners of the SMEs in Nakuru County were male. Respondents were requested to indicate their age brackets. Majority of the respondents who were 38% were between 30-40 years, 37% were above 50 years, 13% were below 30 years, while 12% were 41-50 years. This implies that majority of owners were middle age.

The respondents were asked to indicate the sector in which their enterprise belonged. Results in figure 4 show that 60% of the respondents were in the trade sector, 33% indicated that they were in manufacturing sector while the remaining 7% indicated to be in the service sector. The respondents were asked to indicate their highest level of education. Results in figure 5 show that 32% of the respondents had their highest level of education being masters level, 30% had bachelor's degree level, while 19% of the remainder indicated to hold diploma and secondary level education consequently , the results imply that, the respondents were expected to understand the questionnaire and give valid response since they had better understanding as guided by the their level of education which in this case majority having masters as the highest level of education.

The respondents were asked to indicate their highest amount earned at the end of the day from sales. Results in table 4.1 show that 18.5% of the respondents earned above 10,000,17.6% earned between 7501-10,000,14.3% earned between 5001-7500,12.6% earned between1001-1500, ,10.9% earned between 2501-5000,another 10.9% earned between 0-500,8.4% indicated to earn between 1501-2500, while the remaining 6.7% indicated to earn between 501-1000.This implies that the SMEs were productive since majority earned above 10,000.

### Filling procedure and tax compliance

The respondents were asked to respond on statements on the contribution of filling procedure on tax compliance. Majority of 75.6% of the respondents agreed with the statement that procedures for tax filing are too complicated, 70.6% agreed with the statement that the tax complexity of laws contribute to wrong tax returns, 60.5% of the respondents agreed that forms taxpayer has to present and combining filings number per year are numerous, 54.7% of the respondents agreed that there are delays in electronic filing and payment systems,75.6% of the respondents agreed that the filling of tax returns online is complex.

On a five point scale, the average mean of the responses was 3.7 which mean that majority of the respondents were agreeing with most of the statements; however the answers were varied as shown by a standard deviation of 1.2.

**Table 2:** Descriptive Statistics of filling procedure and tax compliance

Statement	Strongly Y disagree E	Disagree	Uncertain In	Agree	Strongly agree	Mean	Standard Deviation
procedures for tax filing are too complicated	6.70%	11.80%	5.90%	31.90%	43.70%	3.94%	1.26
The tax complexity of laws contribute to wrong tax Returns	4.20%	5.90%	19.30%	47.10%	23.50%	3.8%	1
Forms taxpayer has to present and combining filings number per year are numerous	10.10%	0.00%	29.40%	40.30%	20.20%	3.61%	1.12
There are delays in electronic filing and payment systems	6.70%	5.90%	32.80%	11.80%	42.90%	3.78%	1.25
The filling of Tax returns online is complex	3.40%	14.30%	6.70%	42.00%	33.60%	3.88%	1.13
<b>Average</b>						<b>3.8%</b>	<b>1.2</b>

## Accountability and tax compliance

The respondents were asked to respond on statements on the contribution of accountability on tax compliance. Majority of 58% of the respondents agreed with the statement that low level of accountability and transparency in the use of public resources creates distrust of the tax system, 59.7% agreed with the statement that misuse of tax revenue by officials entrusted with its management affects tax morale thus leading to evasion, 59.7% of the respondents agreed that lack of rule of law reduces the transparency of public institutions and fosters distrust among the citizens thus affecting citizens' willingness to pay tax, 61.4% of the respondents agreed that Taxpayers will be more compliance if government use tax monies wisely by getting benefits for the taxes paid in terms of public goods and social amenities, 58% of the respondents agreed that Tax payers are apprehensive of the need for paying taxes when governments are not accountable. On a five point scale, the average mean of the responses was 3.6 which mean that majority of the respondents were agreeing with most of the statements; however the answers were varied as shown by a standard deviation of 1.2.

### Descriptive Statistics of accountability and tax compliance

Statement	Strongly disagreed	Disagreed	Uncertain	Agree	Strongly agree	Mean	Standard Deviation
Low level of accountability and transparency in the use of public resources creates distrust of the tax system	7.60%	12.60%	21.80%	24.40%	33.60%	3.64	1.27
Misuse of tax revenue by officials entrusted with its management affects tax morale thus leading to evasion	7.60%	10.10%	22.70%	29.40%	30.30%	3.65	1.23
Lack of rule of law reduces the transparency of public institutions and fosters distrust among the citizens thus affecting citizens' willingness to pay tax	7.60%	2.50%	30.30%	30.30%	29.40%	3.71	1.14
Taxpayers will be more compliance if government use tax monies wisely by getting benefits for the taxes paid in terms of public goods and social amenities	8.40%	13.40%	16.80%	37.00%	24.40%	3.55	1.23
Tax payers are apprehensive of the need for paying taxes when governments are not accountable.	11.80%	11.80%	18.50%	24.40%	33.60%	3.56	1.37
<b>Average</b>						<b>3.6</b>	<b>1.2</b>

### Correlation Matrix

Variable		Tax compliance	Filing procedures	Accountability	
Tax compliance	Pearson Correlation	1			
	Sig. (2-tailed)				
Filing procedures	Pearson Correlation	.543**	0.172	.546*	1
	Sig. (2-tailed)	0.000	0.061	*0.000	
Accountability	Pearson Correlation	.522**	0.057	.554** .642*	1
	Sig. (2-tailed)	0.000	0.54	*0.000	0.000

### Regression Analysis study variables

The results presented in table 5 present the fitness of model used of the regression model in explaining the study phenomena. Filing procedure and accountability were found to be satisfactory variables in explaining tax compliance. This was supported by coefficient of determination also known as the R square of 47.5%. This means that filling procedure accountability explain 47.5% of the variations in the dependent variable which is tax compliance. This results further means that the model applied to link the relationship of the variables was satisfactory.

**Table 5: Model Fitness**

Model	R	R Square	Adjusted R Square	Std. Error of the Estimate
1	.689a	0.475	0.457	0.58127

**a Predictors: (Constant), , Taxpayer knowledge, Tax rates,**

**Table 6: Regression of Coefficients**

	B	Std. Error	t	Sig.
(Constant)	0.902	0.388	2.327	0.022
Filing procedures	0.203	0.087	2.35	0.021
Accountability	0.198	0.068	2.911	0.030

The optimal model was therefore;

The multiple regression models will be laid as below.

$$Y = 0.902 + 0.203X_1 + 0.198X_2$$

Where: Y=Tax compliance, X<sub>1</sub>=Filing procedure, X<sub>2</sub>=Accountability

### Conclusions and Recommendations

The study concluded that procedures for tax filing are too complicated, the tax complexity of laws contribute to wrong tax returns, Forms taxpayer has to present and combining filings number per year are numerous, there are delays in electronic filing and payment systems and that The filling of Tax returns online is complex therefore low level of tax compliance among the SMEs. The study also concluded that low level of accountability and transparency in the use of

public resources creates distrust of the tax system, misuse of tax revenue by officials entrusted with its management affects tax morale thus leading to evasion, lack of rule of law reduces the transparency of public institutions and fosters distrust among the citizens thus affecting citizens' willingness to pay tax, Taxpayers will be more compliance if government use tax monies wisely by getting benefits for the taxes paid in terms of public goods and social amenities and Tax payers are apprehensive of the need for paying taxes when governments are not accountable hence the low level of tax compliance. The study recommended that tax laws should not be complex so as to not contribute to wrong tax returns, also lessen measure of time taken for organizations to round out various structures with comparative data, moreover reduce time taken holding up in line to returns filing and make instalment at tax office. The study also recommended that there to be tax accountability and transparency with greater emphasis on the various kind of taxes such as personal income tax, companies income tax petroleum profit tax, duties and value added tax since they are perceived to have a direct correction with the Gross Domestic Product.

## References

- Ajao, A. T., Adebayo, G. B., & Yakubu, S. E. (2017). Bioremediation of Textile Industrial Effluent using mixed culture of *Pseudomonas aeruginosa* and *Bacillus subtilis* immobilized on agaragar in a Bioreactor. *Journal of Microbiology and Biotechnology Research*, 1(3), 50-56.
- Akinboade, O.A. (2015). Correlates of Tax Compliance of Small and Medium Size *Businesses in Cameroon*, *Managing Global Transitions*, 13(4), 389-413
- AlNajjar, F.K., & Riahi-Belkaoui, A. (2001). Empirical validation of a general model of growth opportunities. *Managerial Finance*, 27(3), 72-90.
- Alstermark, B., & Isa, T. (2012). Circuits for skilled reaching and grasping. *Annual review of neuroscience*, 35, 559-578.
- American Association of University Professors. Committee Z., & American Association of University Professors. (1998). *The Annual Report on the Economic Status of the Profession*.
- Bame-Aldred, C. W., Cullen, J. B., Martin, K. D., & Parboteeah, K. P. (2013). National culture and firm-level tax evasion. *Journal of Business Research*, 66(3), 390-396.
- Brautigam, et al. (2008). *Taxation and state-building in developing countries*. Capacity and consent, Cambridge University Press.
- Cheeseman, N., & Griffiths, R. (2005). Increasing tax revenue in sub-Saharan Africa: The case of Kenya. *OCGG Economy Analysis*, (6).
- Fishbein, M., & Ajzen, I. (1975). *Belief, attitude, intention and behavior: An introduction to theory and research*.
- Fishlow, A., & Friedman, J. (1994). Tax evasion, inflation and stabilization. *Journal of Development Economics*, 43(1), 105-123.
- Itashiki, M. R. (2011). *Explaining "everyday crime": A test of anomie and relative deprivation theory*. University of North Texas.
- Karingi, S., Wanjala, B., Nyamunga, J., Okello, A., Pambah, E., and Nyakang'o, E. (2005). *Tax Reform Experience in Kenya*. Kenya Institute for Public Policy Research and Analysis, KIPPRA Working Paper No. 13
- Kenya. (2005). *Sessional Paper No. 2 of 2005 on Development of Micro and Small Enterprises for Wealth and Employment Creation for Poverty Reduction (No. 2)*. Government Printer.
- Kirchler, E. (2007). *The economic psychology of tax behaviour*. Cambridge: Cambridge University Press.
- Lumumba, O. M., Wanjoli, M. S., Maguta, P. O., & Mokoro, J. M. (2010). Taxpayers' attitudes and tax compliance behavior in Kenya: How the taxpayers' attitudes influence compliance behavior among SMEs Business income earners in Kerugoya Town, Kirinyaga District. *African Journal of Business and Management*
- Magiya, S.O. (2016). *Determinants of tax compliance among small and medium sized enterprises in Nairobi east tax district*. Unpublished Nairobi University Thesis.

- Malhotra, I., Dent, A., Mungai, P., Wamachi, A., Ouma, J. H., Narum, D. L., ... & King, C. L. (2009). Can prenatal malaria exposure produce an immune tolerant phenotype?: A prospective birth cohort study in Kenya. *PLoS medicine*, 6(7), e1000116.
- Messner, S. F., & Rosenfeld, R. (2001). *An institutional-anomie theory of crime. Explaining criminals and crime*, 151-160.
- Mugenda, M., & Mugenda, G. (2013). *Research Methods: Qualitative and Quantitative approaches*. Nairobi: Acts Press.
- Nakuru County Government Records. (2017). *Business Permit Register- 2015*. Nakuru County Government.
- Ndemo, A. M. (2015). Determinants of Tax Efficiency Perceptions by Domestic Taxpayers in Kenya: The Case of Nairobi. *International Journal of Economics, Finance and Management Sciences*, 3 (5), 541-545
- Singelis, T. M., Triandis, H. C., Bhawuk, D. P., & Gelfand, M. J. (1995). Horizontal and vertical dimensions of individualism and collectivism: A theoretical and measurement refinement. *Cross-cultural research*, 29(3), 240-275.
- Thiga, M.N., & Muturi, W. (2015). Factors That Influence Compliance with Tax Laws among Small and Medium Sized Enterprises in Kenya. *International Journal of Scientific and Research*